

Model EL-IB

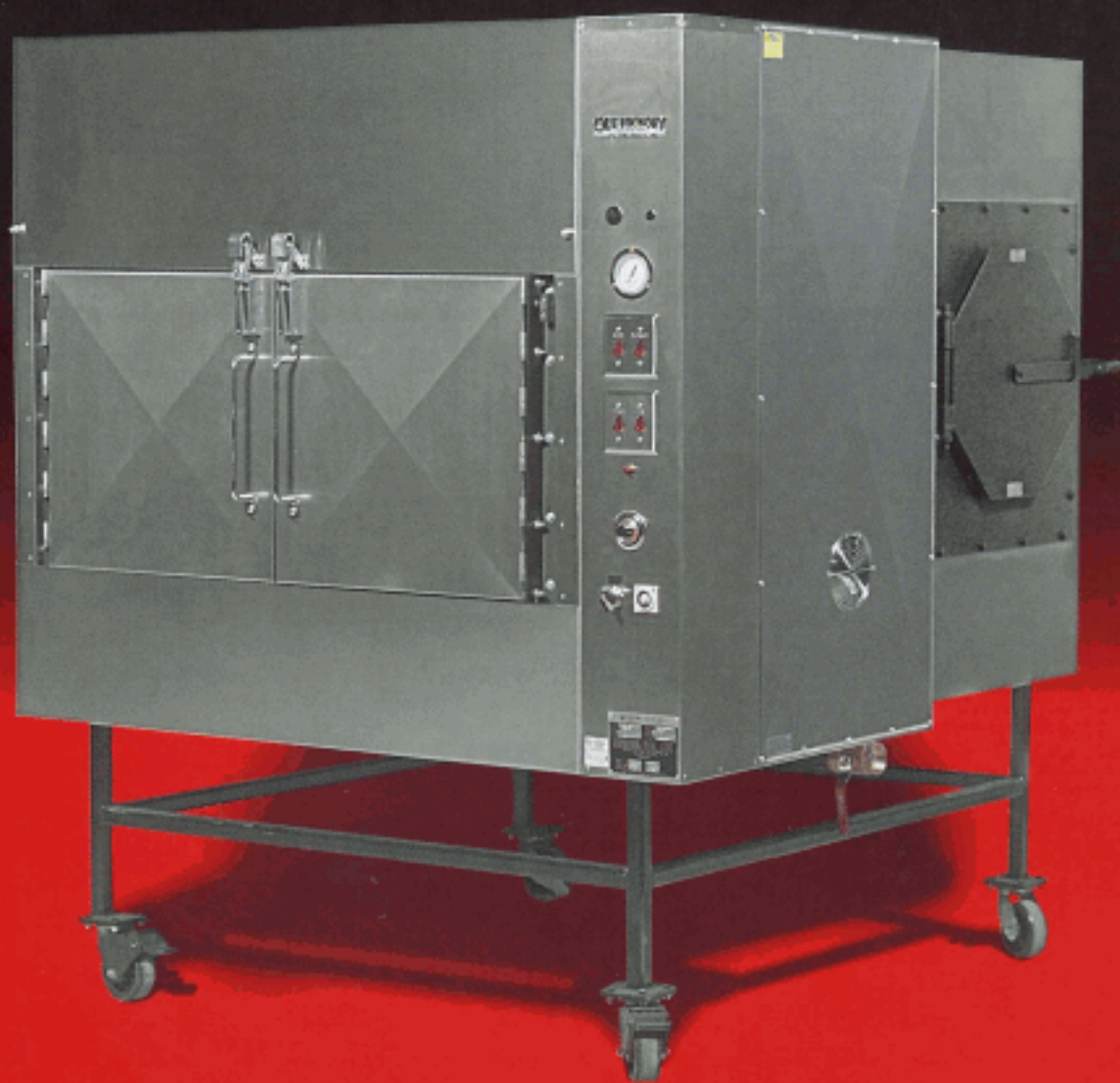

**OLE HICKORY
PITS**

WOOD BURNING BARBECUE PITS

Revolving Racks: (15) 12" x 42", Cooking Space: 52.5 Sq. Ft.

Arleique Smoker Sales

P.O. Box 846

Mt. Juliet, TN 37122

Office-615-758-8749--Cell-615-477-7447

MODEL EL-IB

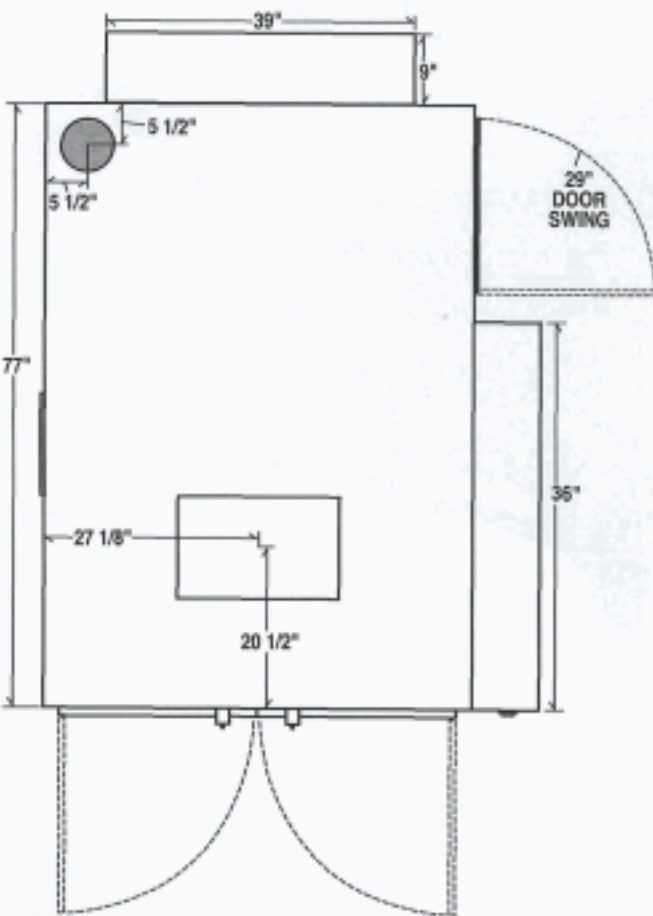
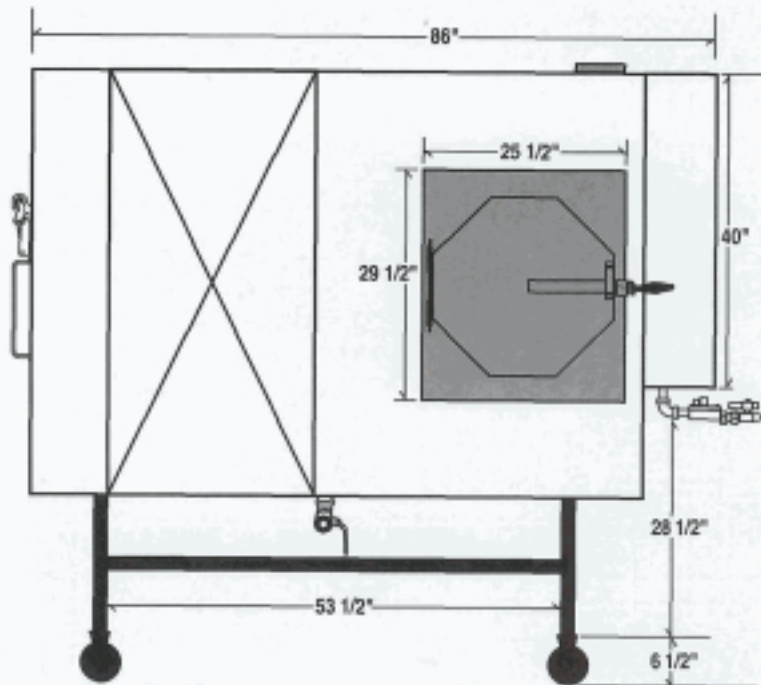
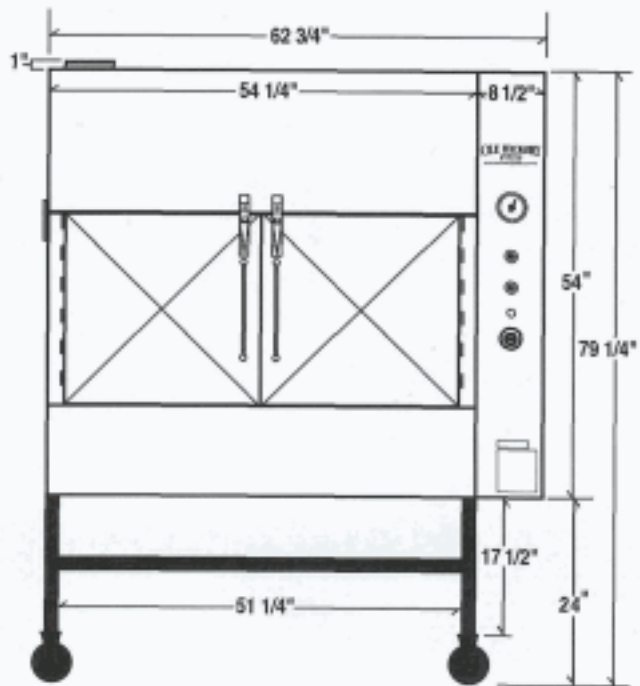

Construction: *Heavy Duty 12 Gauge Steel Interior* (100% welded & inspected seams) *Tubular Steel Frame*, 22 gauge stainless steel exterior; *Mineral Wool Insulation- rated 1200 degrees F.* (contains no Asbestos or Fiberglass)

Electrical: 110 Volts, 60HZ, Single Phase, 15 Amp - AVOID NON-GROUNDED EXTENSION CORDS.

Gas Burner: 65,000 BTU Burner with Electronic Ignition, available for L.P. or Natural Gas.

Firebox: Two (2) regular fireplace size logs will last for up to 6 hours of cooking. Air over firebox circulation.

Temperature Range: Thermostat control range 100 degrees F. to 325 degrees F.

Upper Limit Control Switch: Extra Safety Feature.

Dial Thermometer: 2 1/2" Diameter.

Heavy Duty Foot Switch: Rotisserie Advance.

Casters: (4) Heavy Duty, ETL Approved.

Convection System: (2) 1/4 HP motors with 10" fan blades provide a mix of both heat and smoke for product consistency.

Flue: 4" diameter.

Grease Drain: 2" Pipe with 2" Ball Valve.

Weight: 2000 lbs, uncrated.

Rotisserie: 15 Racks, 12" X 42", 52.5 Sq. Ft. Cooking Surface. Nickel-chrome (stainless available at extra cost) Removable for easy cleaning.

Rotisserie Drive: Heavy Duty 1/4 HP Motor - long lasting chain drive system utilizing gear reduction.

